



2S7 Pion Front Cabin/Driver Compartment (for Trumpeter kit)

Working with 3D printed material:

The 3D material used is brittle and may break when handled incorrectly. Take care in removing parts from the frame. Some parts have been hollowed out to reduce printing costs. Holes are placed out of site and can be filled with modeling putty or plastic sheet.

3D printing of this conversion set was done in a special resin bath. Due to this production method a wax residue can remain on the parts. Cleaning them is not difficult but necessary: Remove parts from the frame and clean them thoroughly using a soft brush and water and dishwashing fluid. It is also possible to use an ultrasonic cleaner with water. Redo cleaning process until water remains clear. A heavier cleaning can be done with white spirit or alcohol.

Use enamel based paint or something like thinned down Mr-surfacer (1000) for the first paint layer. This seals any 3D printing residue that might be left from the printing process. When left unpainted the 3D material may start to 'sweat' and cleaning must be redone.

Working with 3D printed material is similar to working with cast resin. Heated parts can be straightened (below 80°) and parts can be glued with superglue.

NOTE: discoloration may occur over time to uncleaned and/or unpainted parts. This will NOT influence the material quality. Please clean thoroughly or redo cleaning.

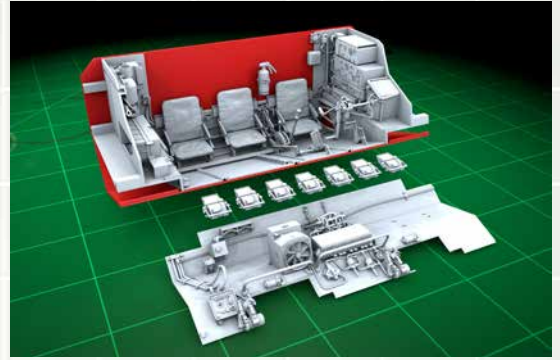

Parts:

- 1 - Floor
- 2 - Right wall
- 3 - Left wall
- 4 - Steering rods (2)
- 5 - Wiring
- 6 - Front wall
- 7 - Switchboard lid
- 8 - Brake lever
- 9 - Periscope top (7)
- 10 - Periscope bottom (7)
- 11 - Seats (3)
- 12 - Break rod
- 13 - Fire extinguisher

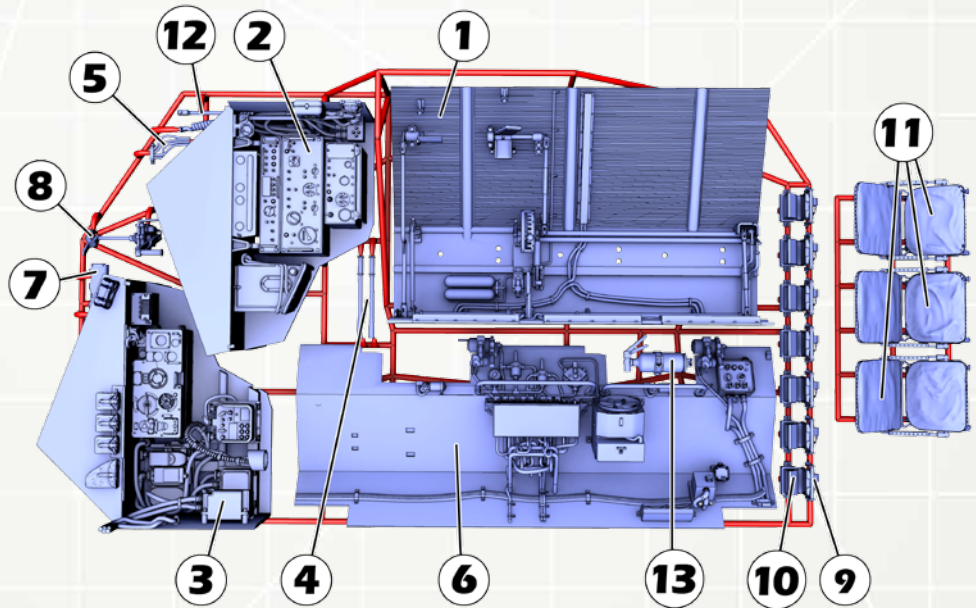

To remove parts, please cut the red parts.

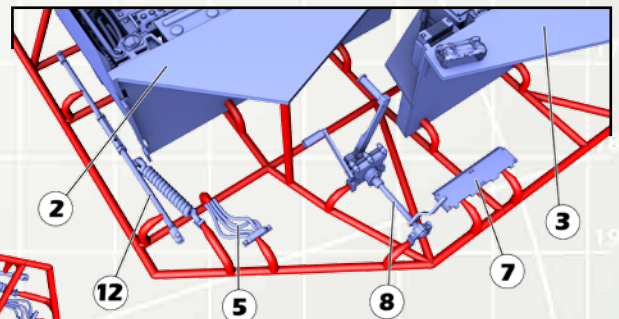
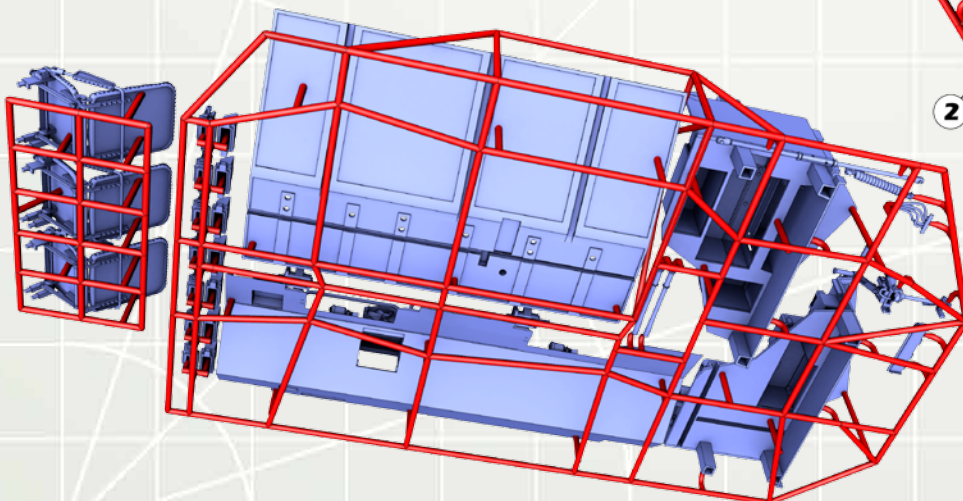

**PARTS ARE FRAGILE,
HANDLE WITH CARE**

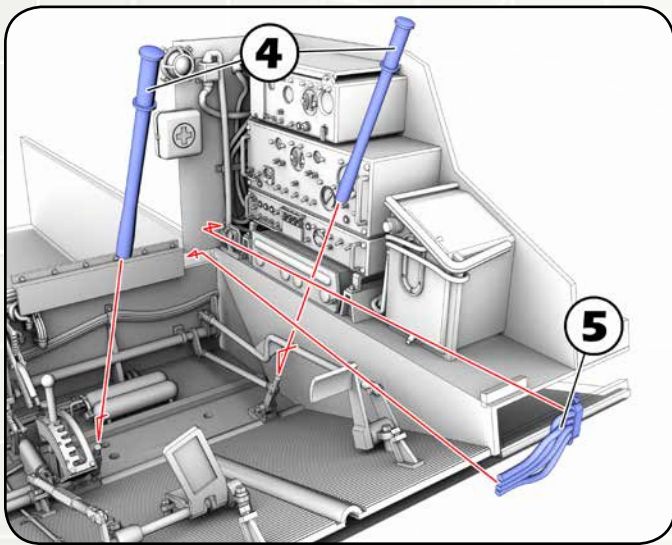
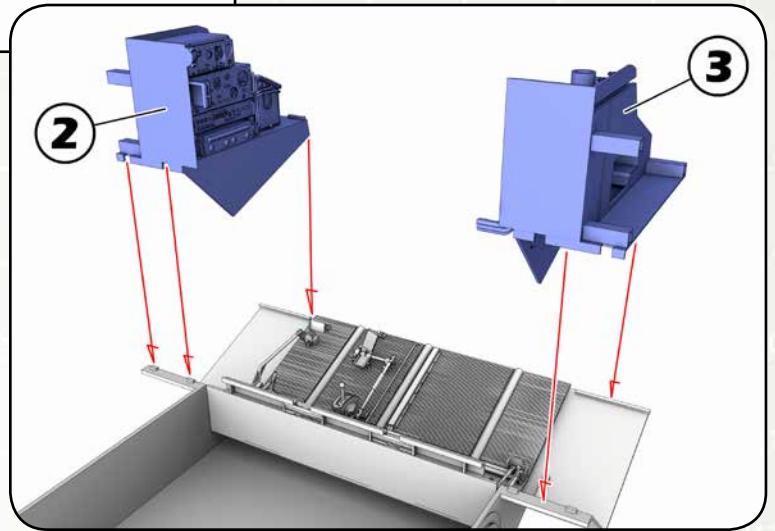
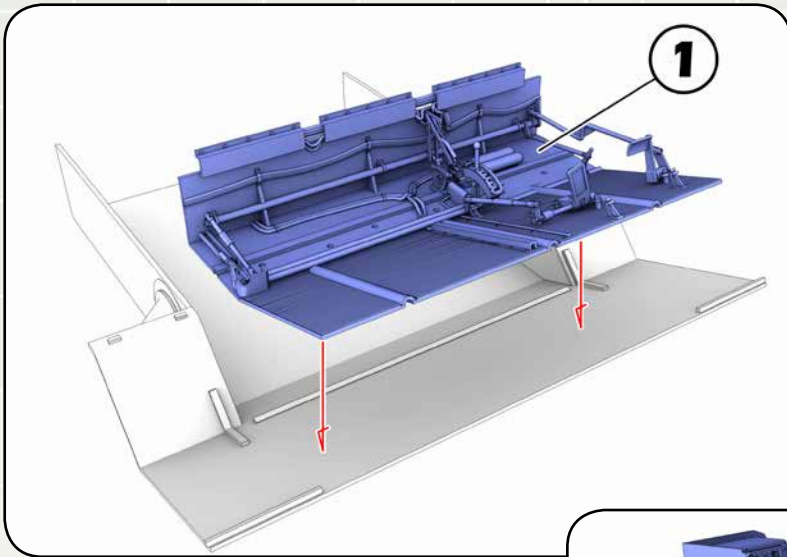

PARTS ARE FRAGILE,
HANDLE WITH CARE

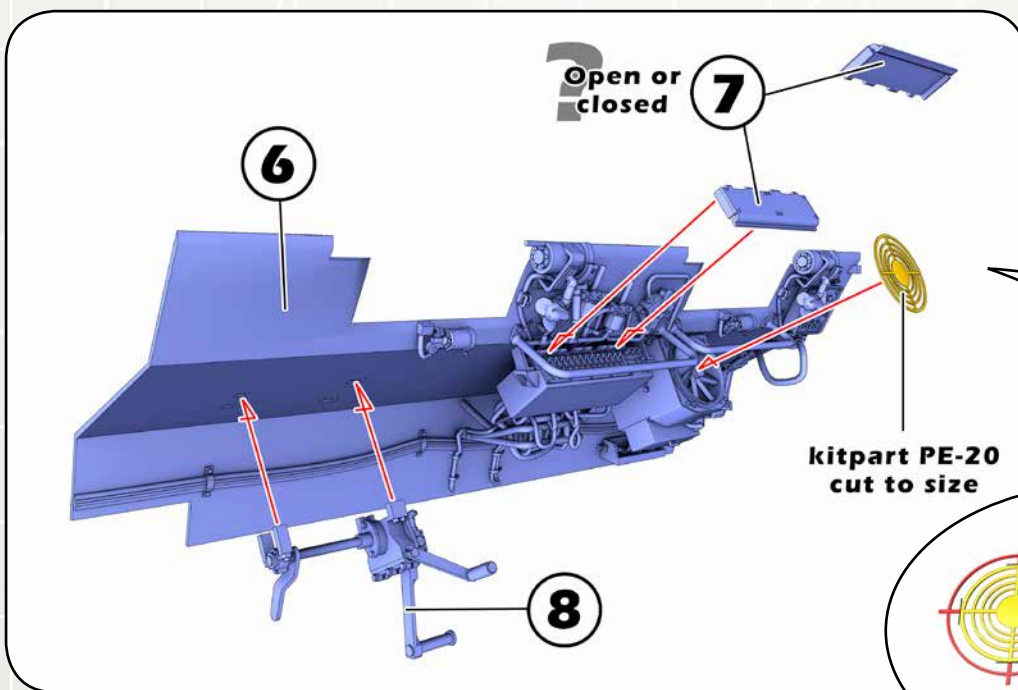

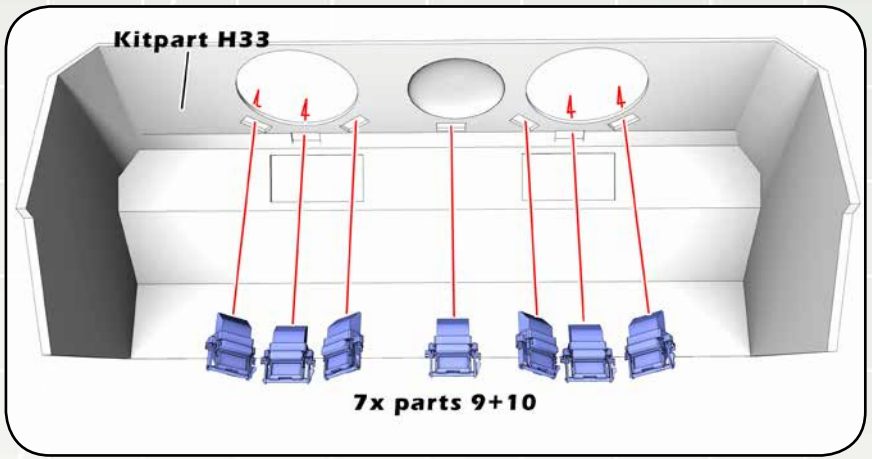
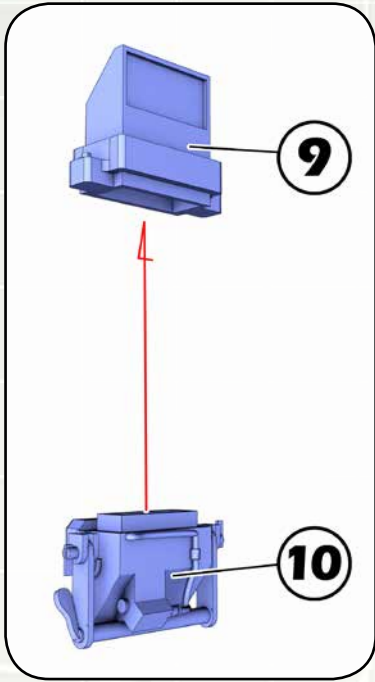

PARTS ARE FRAGILE,
HANDLE WITH CARE

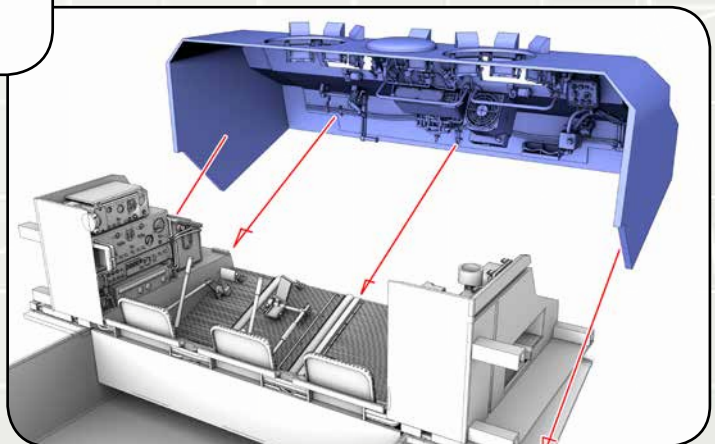
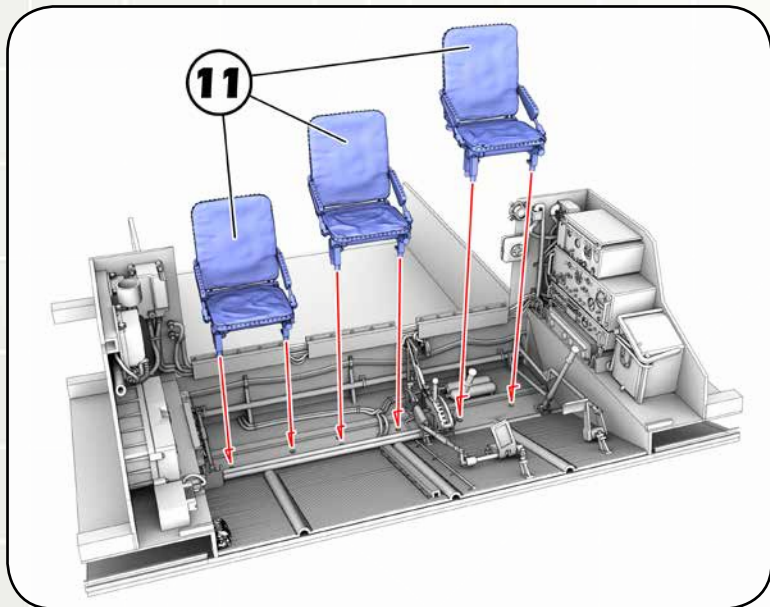
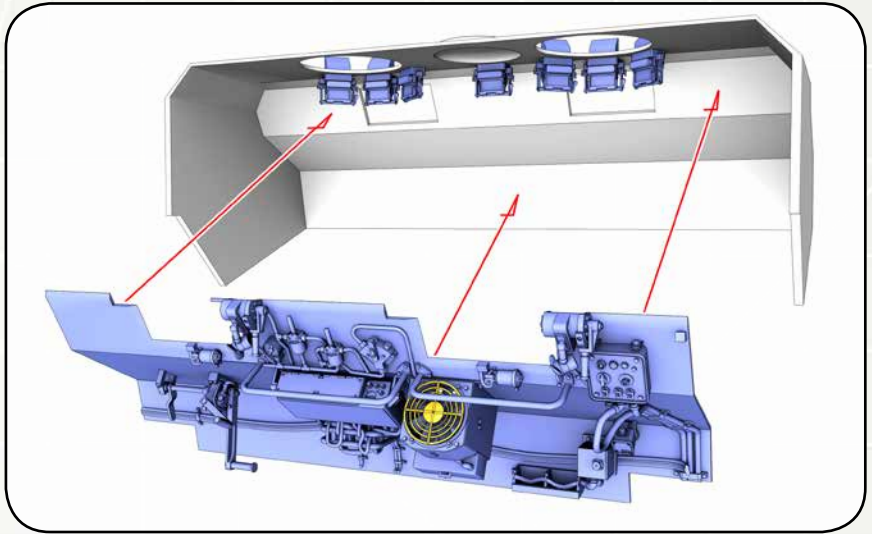

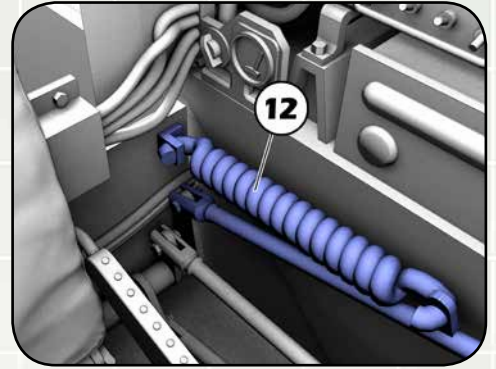
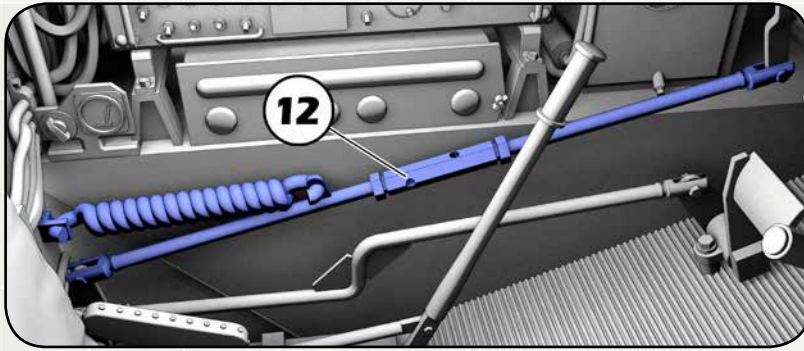

PARTS ARE FRAGILE, HANDLE WITH CARE

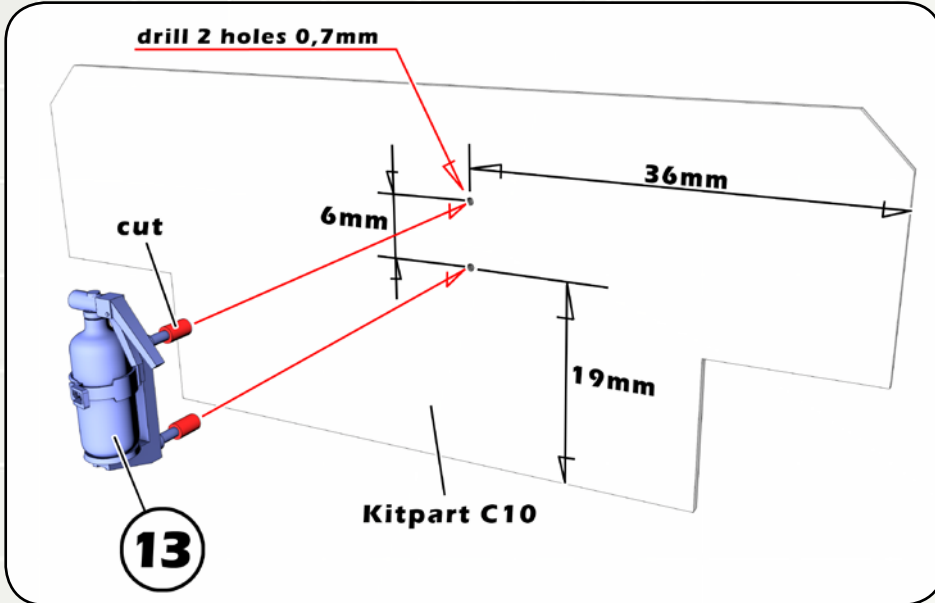
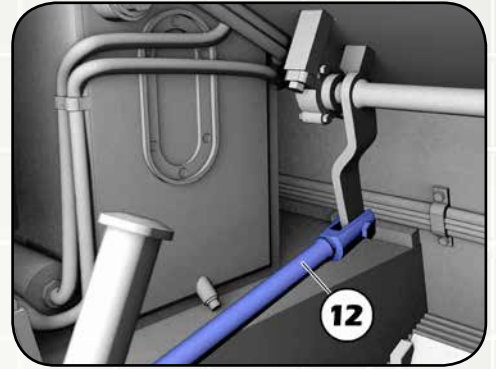

Pictures used courtesy of Wings & Wheels Publications.
WWP G043: PION 2S7 In Detail

Have a look at our two other 2S7 Pion conversion sets at www.3dinscale.com

